

DXD-A027/A

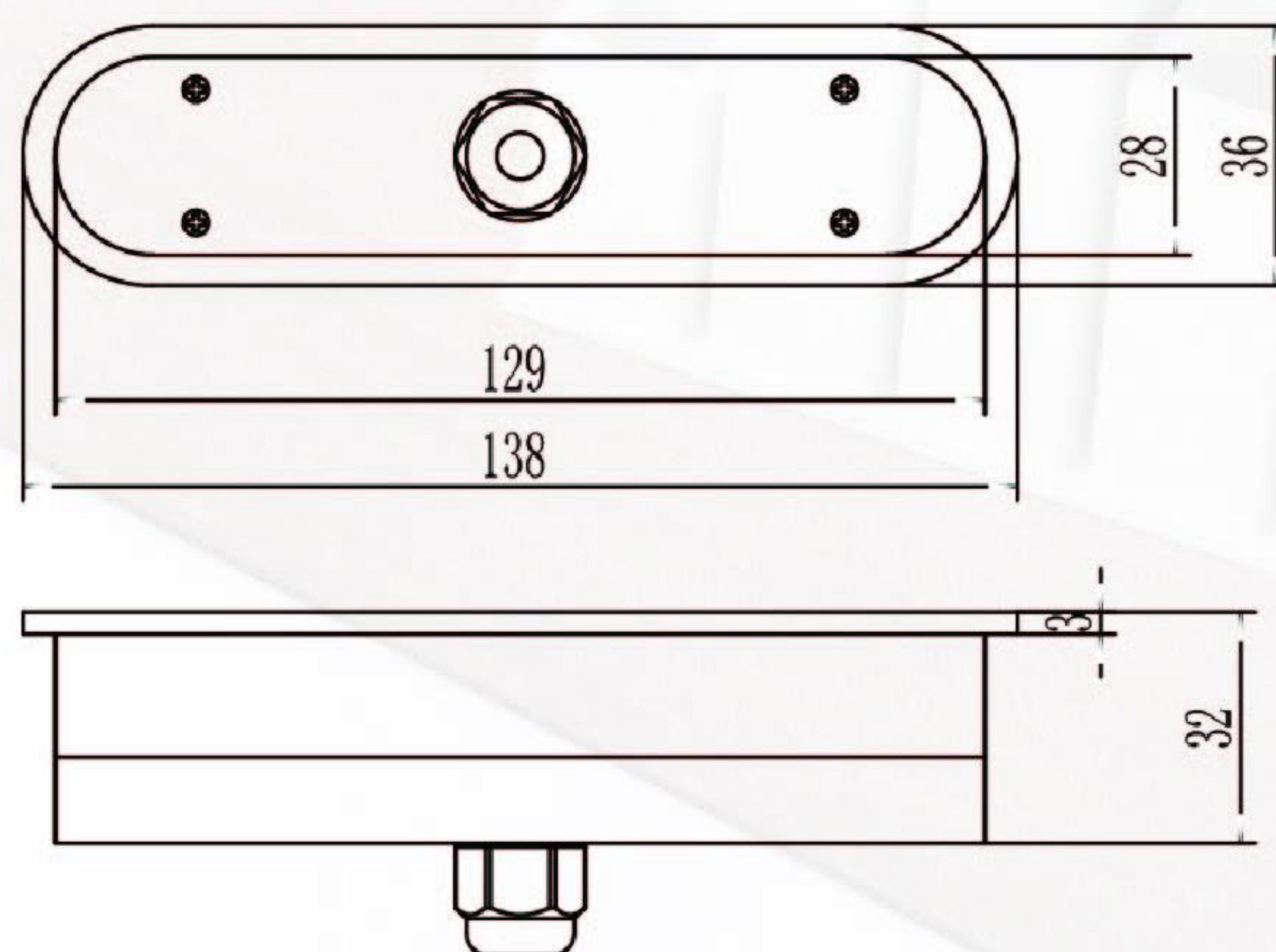

IPX5



项目 Project	负载及参数 Parameters	型号 Model	DXD-A027/A	
操作界面 Operation Interface	触摸感应按键技术 Touch key technology	电容式感应 Capacitive touch key	●	
功能 Functions	水泵控制 Water pump	水泵 Water pump AC230V/3HP MAX	●	
	风泵控制 Blower	风泵 Blower AC230V/1.5HP MAX	●	
	水底灯控制 Bottom light	水底灯 Bottom light AC12V/3W MAX	●	
	臭氧控制 Ozone	臭氧发生器 Ozone generator AC12V/9W MAX	*	
	空气调节 Air adjust	空气调节器 Air adjust AC12V/3W MAX		*
		冲浪电磁阀 Surfing valve DC12V/7W MAX		*
	恒温控制 Thermostatic heating	恒温器 Heater AC230V/3000W MAX	*	
	自动清洗 Auto cleaning	清洗电磁阀 Clean valve DC12V/7W MAX	*	
	FM收音 FM radio	喇叭 Speaker 8Ω/10W MAX	●	
	CD	喇叭 Speaker 8Ω/10W MAX	*	
	MP3	喇叭 Speaker 8Ω/10W MAX	*	
	蓝牙 Blue tooth	喇叭 Speaker 8Ω/10W MAX	*	
	童锁 Child lock	-	●	
	水位检测 Water level detection	水位探针 Probe detector		*
电容式水位感应器 Capacitive sensor			*	

注：1. “●” 表示标配功能；2. “*” 表示选配功能；3. 以上所有产品都可以按照AC110V/60Hz要求定制。

1. “●” Stands for the standard functions. 2. “*” Stands for the optional functions. 3. All these models can also be designed according to AC110V/60Hz.