

DXD-8A

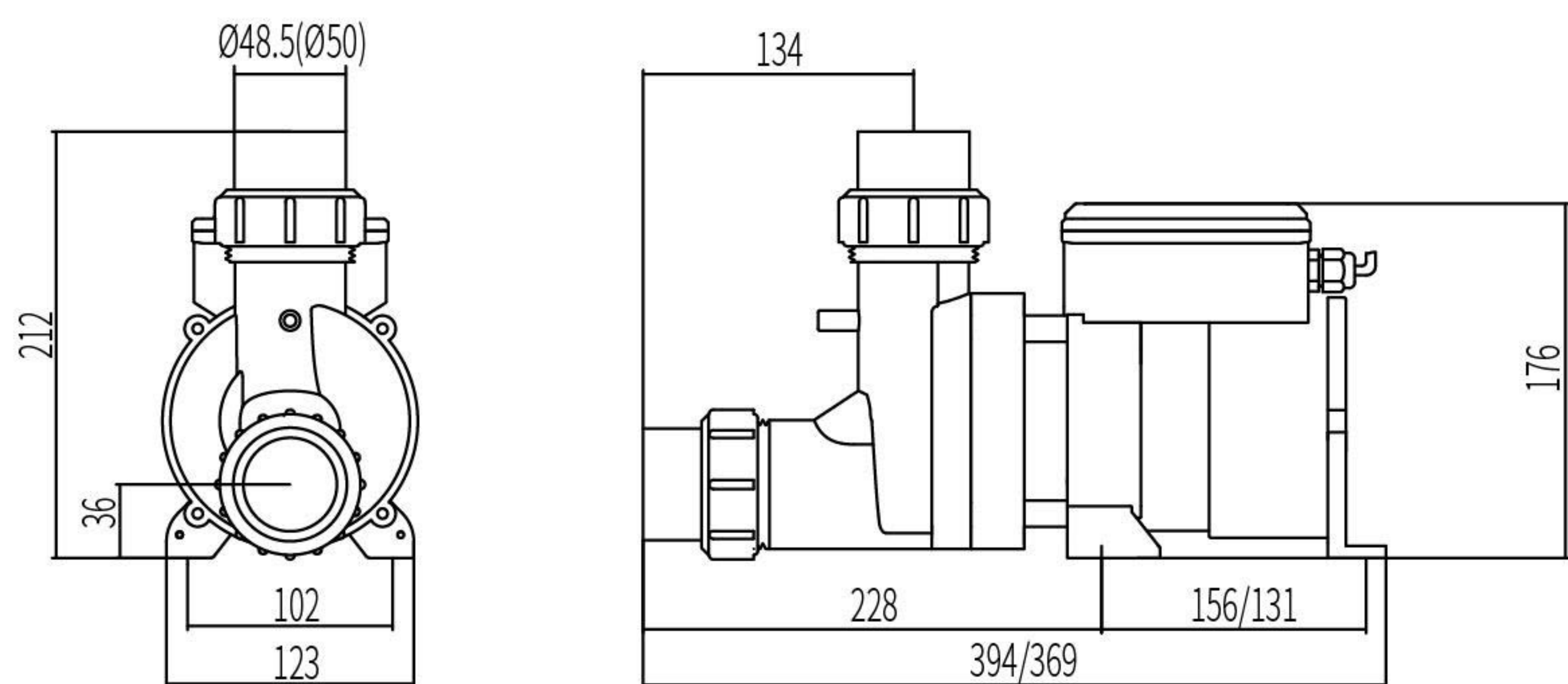

DXD-8E

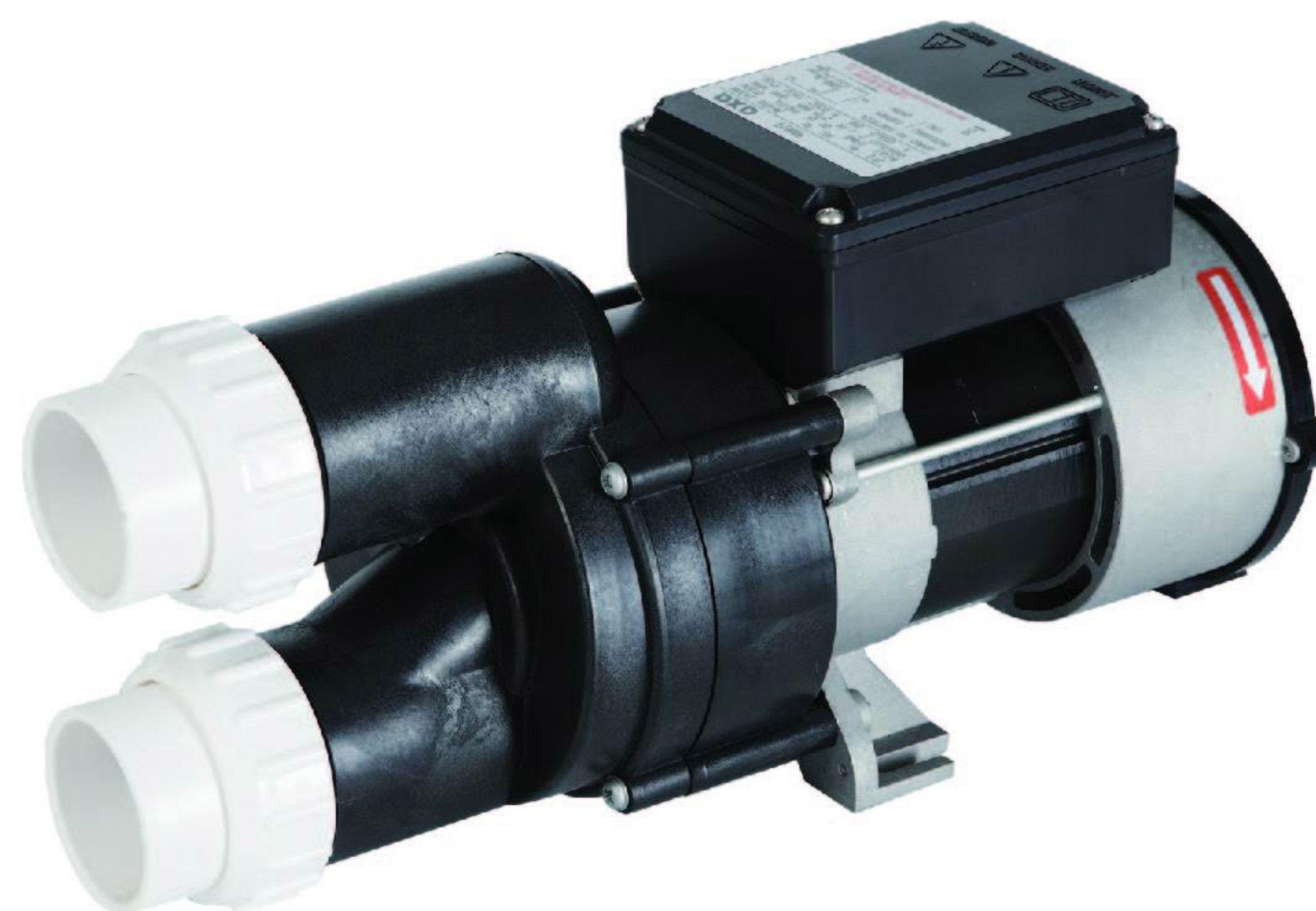
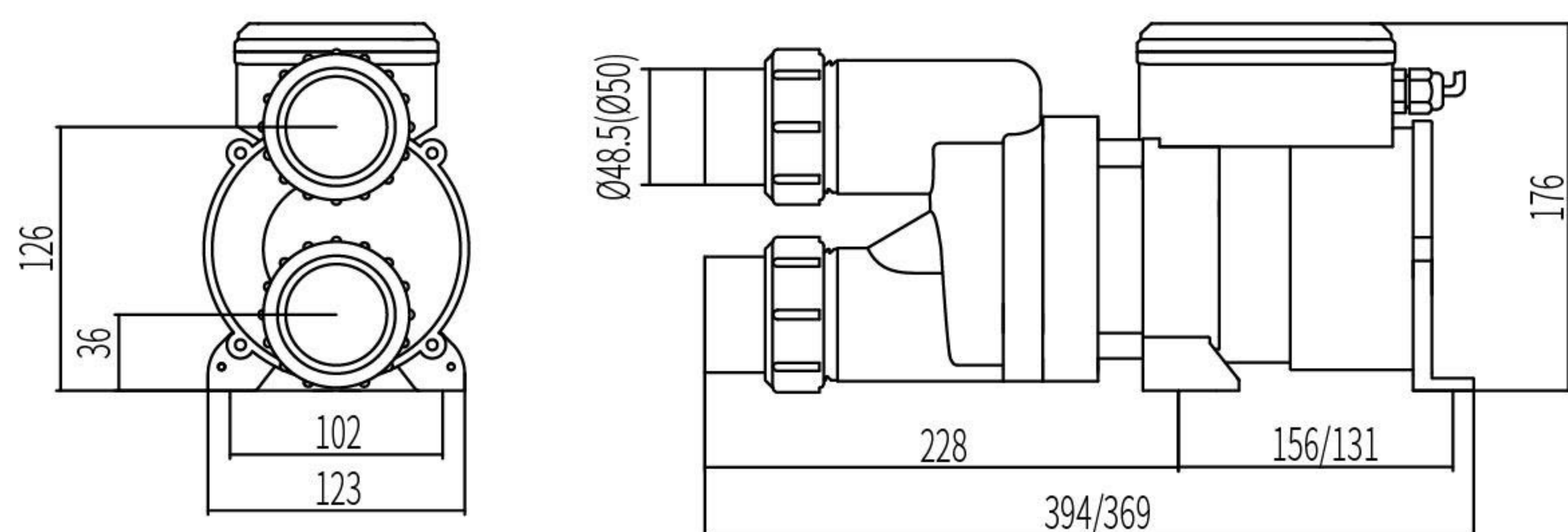

性能曲线 Performance Curves

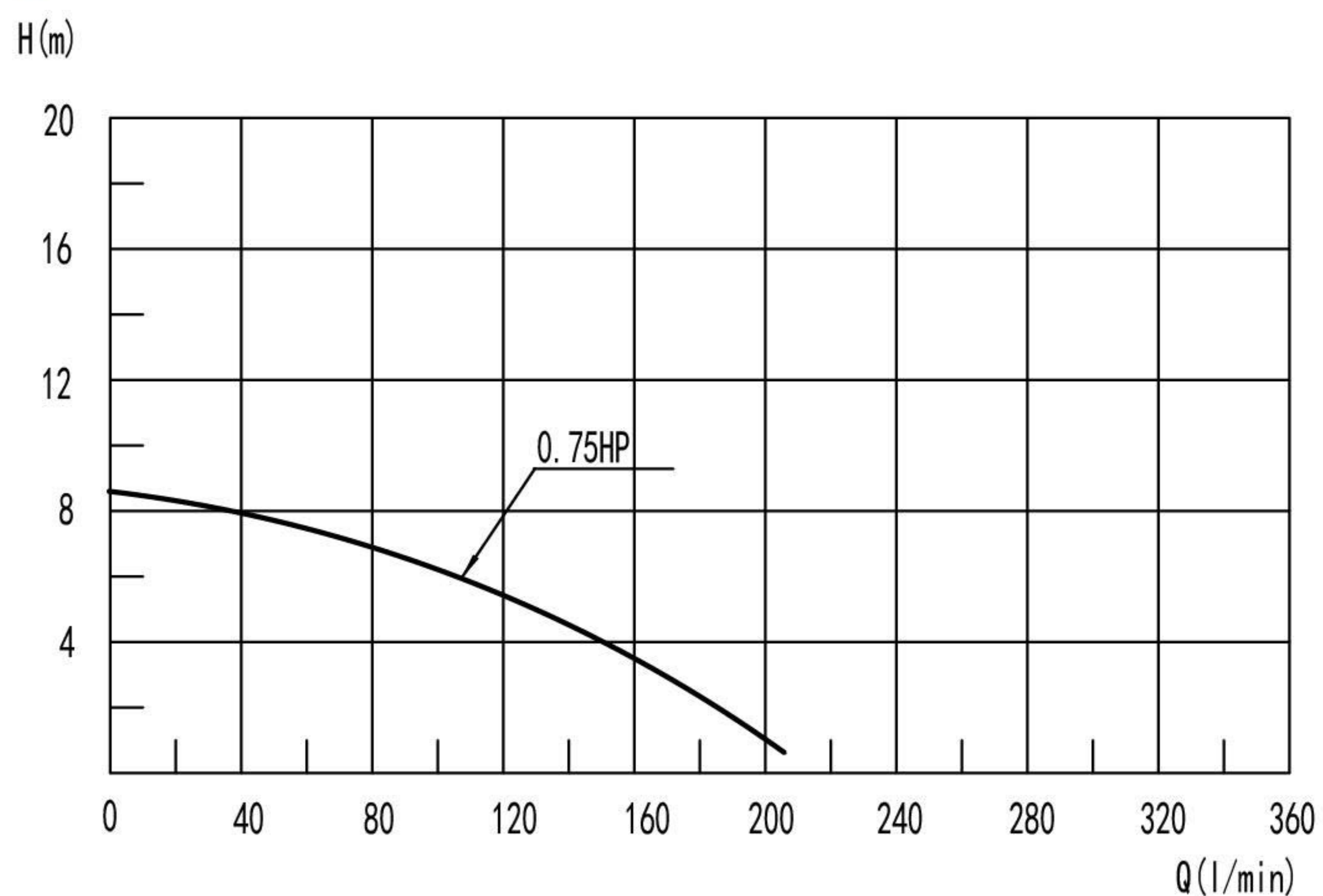

工作条件 Working Conditions

- 介质温度:5-50°C
- 环境温度:≤50°C
- 湿度:65%RH
- 最大工作压力:0.4Mpa
- Medium temperature:5-50°C
- Environmental temperature:≤50°C
- Humidity: 65% RH
- Max.working pressure: 0.4Mpa

技术参数 Technical Parameter List

型号 Model	电压 Voltage	功率 Power		转速 Rotating Speed (r/min)	最大扬程 Maximum Lift (m)	最大流量 Maximum Flow (l/min)	绝缘等级 Insulation Class	毛重 Gross Weight (kg)	认证 Certification
		Kw	HP						
DXD-8A	230v/50Hz	0.55	0.75	2850	8.5	208	F	6.0	
DXD-8C	230v/60Hz	0.55	0.75	3450	8.5	208	F	6.0	
DXD-8D	115v/60Hz	0.55	0.75	3450	8.5	208	F	5.5	
DXD-8E	230v/50Hz	0.55	0.75	2850	8.5	208	F	6.0	
DXD-8F	230v/60Hz	0.55	0.75	3450	8.5	208	F	6.0	
DXD-8G	115v/60Hz	0.55	0.75	3450	8.5	208	F	5.5	

包装 (Packing): 370mm×150mm×195mm