

## DXD-310FM

## 工作条件 Working Conditions

介质温度: 5-50°C

环境温度: ≤50°C

湿度: 65% RH

最大工作压力: 0.4Mpa

Medium temperature: 5-50°C

Environmental temperature: ≤50°C

Humidity: 65% RH

Max.working pressure: 0.4Mpa

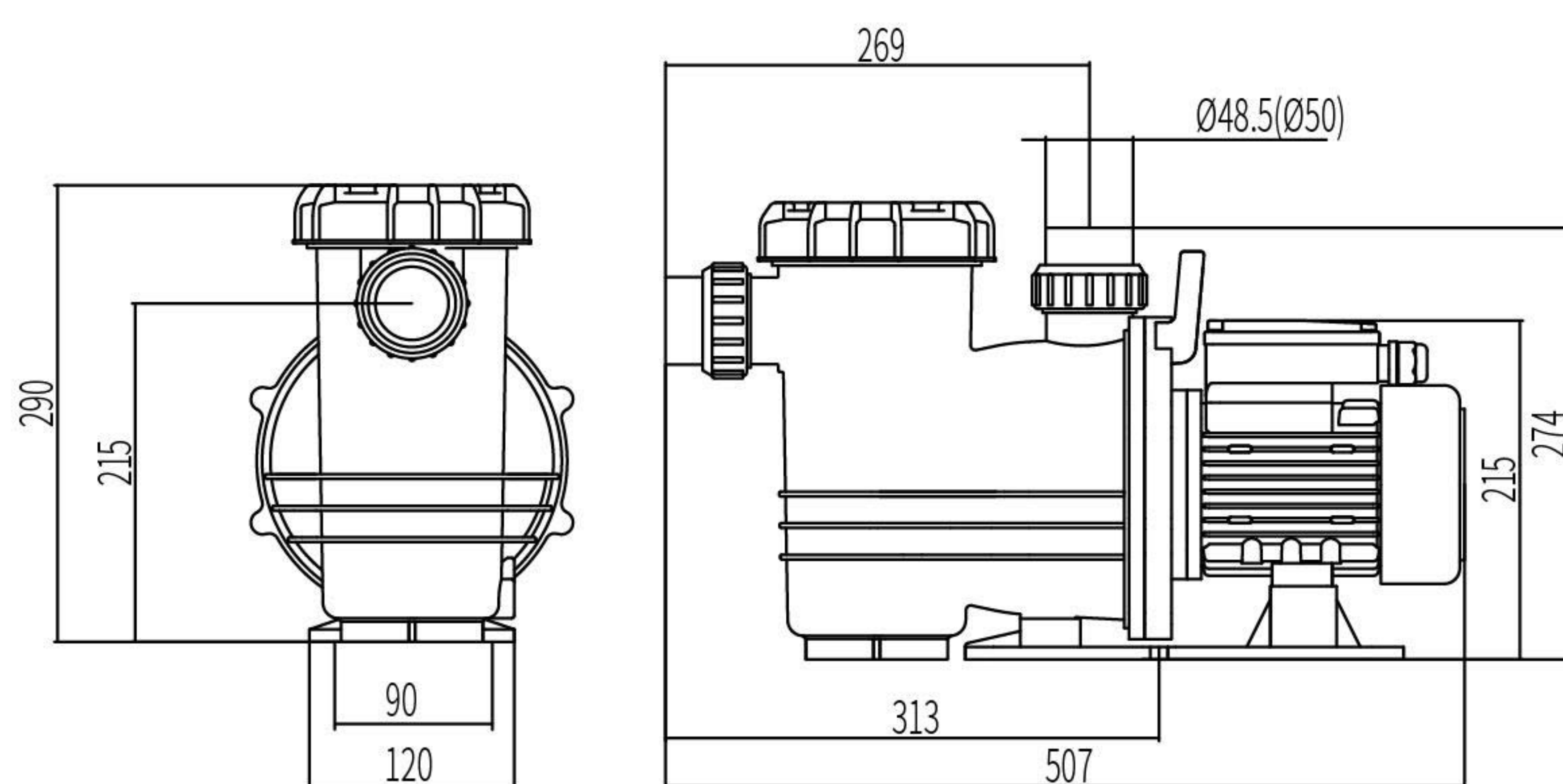

## 性能曲线 Performance Curves

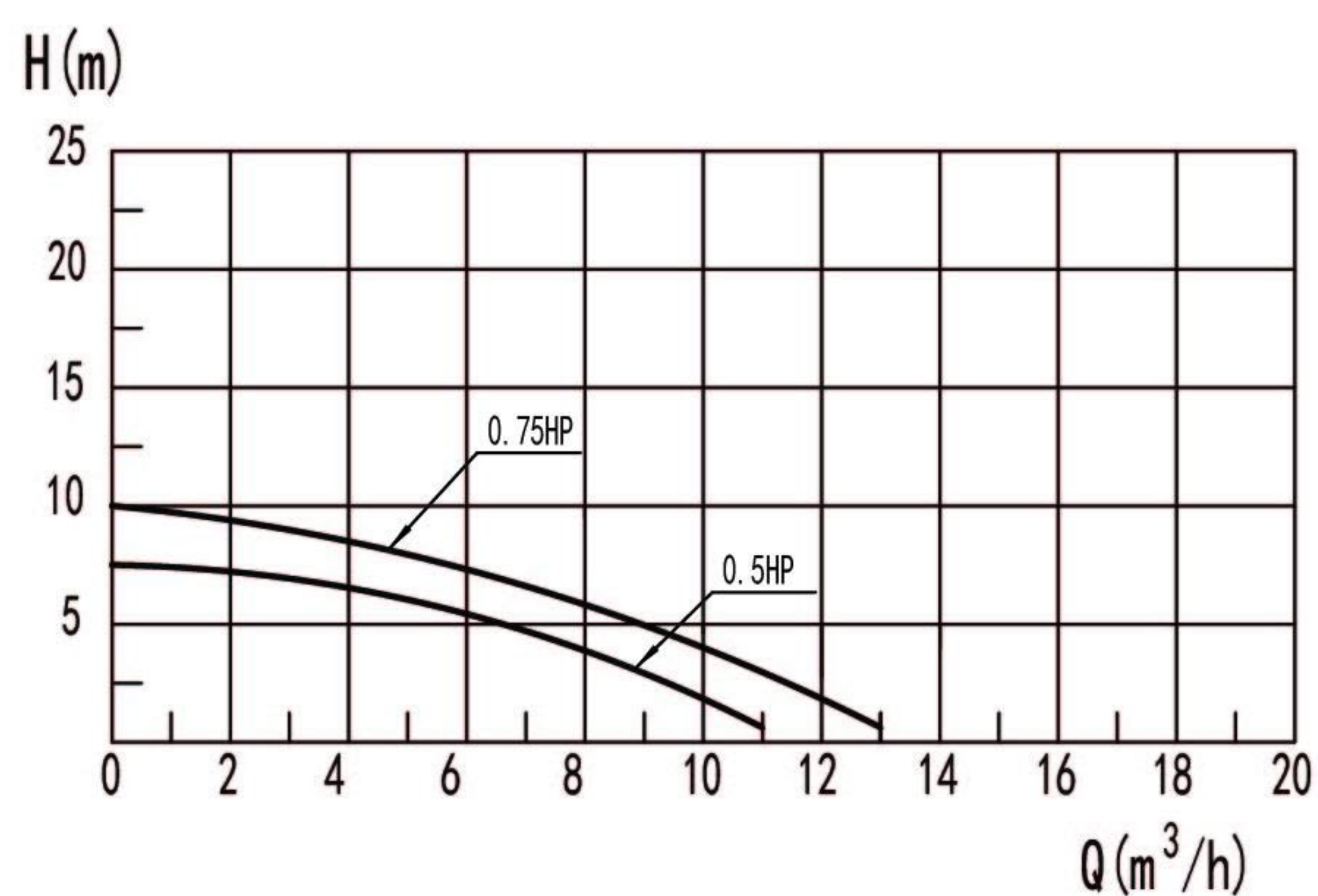

IEC 60335-1:2010  
IEC 60335-1:2010/AMD1:2013  
IEC 60335-1:2010/AMD2:2016  
IEC 60335-2-41:2012



AS/NZS 60335.2.41:2013 Inc A1  
AS/NZS 60335.1:2020



E351970



EN 60335-1:2012/A2:2019  
EN 60335-2-41:2003/A2:2010  
EN 62233:2008



EN 60335-1:2012/A2:2019  
EN 60335-2-41:2003/A2:2010  
EN 62233:2008

## 技术参数 Technical Parameter List

型号 Model	电压 Voltage	功率 Power		转速 Rotating Speed (r/min)	最大扬程 Maximum Lift (m)	最大流量 Maximum Flow (m³/h)	绝缘等级 Insulation Class	防护等级 Protection Grade	毛重 Gross Weight (kg)	认证 Certification
		Kw	HP							
DXD-310FM-350	230v/50Hz	0.35	0.5	2850	7	11	F	IP X5	8.0	IECEE SAA TUV CE
DXD-310FM-550	230v/50Hz	0.55	0.75	2850	10	14	F	IP X5	10.0	IECEE SAA TUV CE
DXD-310FM-350	115v/60Hz	0.35	0.5	3450	7	11	F	IP X5	8.0	cRU US
DXD-310FM-550	115v/60Hz	0.55	0.75	3450	10	14	F	IP X5	10.0	cRU US

包装 (Packing): 625mm×265mm×400mm

可选配定时功能和无水保护装置 Optional function: Timer&No Water Protection